

RENAULT TRUCKS MASTER



RENAULT TRUCKS MASTER



CHASSIS CAB OR PLATFORM CAB VERSION

RENAULT TRUCKS MASTER RED EDITION:
ONLY AT RENAULT TRUCKS P 04

**READY TO WORK FOR ALL
ACTIVITES P 06**

EURO 6 ENGINE, ELECTRIC MOTOR P 08

READY TO BODY FOR ALL ACTIVITIES P 10

OUTSTANDING LOADING CAPACITY
AND VOLUME P 12

ALWAYS READY TO WORK P 14

ROBUST AND RELIABLE AT ALL TIMES P 16

COMFORTABLE ON ALL SURFACES P 18

AT YOUR SIDE, WHENEVER, WHEREVER P 20

**BECAUSE A UTILITY VEHICLE
MUST MAKE YOUR WORK
EASIER P 22**

EVERYTHING WITHIN REACH P 24

COMFORTABLE WORKING SPACE IN THE CAB P 26

WORKING COMFORT P 28

**WORK IN PERFECT
SAFETY P 30**

SAFETY COMES FIRST P 32

OPTIMAL VISIBILITY IN ALL WEATHERS P 34



VAN VERSION

TECHNICAL CHARACTERISTICS P 36

RANGE SUMMARY	P 38
DRIVETRAIN	P 39
BRAKING AND TYRES	P 39
CHASSIS CAB WEIGHTS AND DIMENSIONS	P 40
CHASSIS CAB	P 41
PLATFORM CAB WEIGHT AND DIMENSIONS	P 42
PLATFORM CAB	P 43
VAN WEIGHT AND DIMENSIONS	P 44
VAN CABS	P 48
FINISHES	P 50
ACCESSORIES	P 51

RENAULT TRUCKS MASTER RED EDITION: ONLY AT RENAULT TRUCKS

Discover Renault Trucks' Master Red EDITION, exclusive to Renault Trucks. Designed by professionals for professionals, it comes equipped with many features as standard for even greater comfort, efficiency and safety.

Red

MASTER
EDITION



TOTALLY ENGINEERED FOR PERFORMANCE

	Van	Chassis Cab	Platform Cab
Extractable passenger shelf	●	●	●
Radiator grille + dashboard chrome finishing	●	●	●
Carbon fabric upholstery*	●	●	●
Red Edition logo	●	●	●
2-button foldable key	●	●	●
Bluetooth radio	●	●	●
ABS + ASR + ESP + Extended Grip + Side Wind Assist	●	●	●
Air conditioning	●	●	●
Cruise control + speed limiter	●	●	●
Automatic running lights and wiper activation	●	●	●
Powered windows with impulse control	●	●	●
Powered and heated rearview mirrors	●	●	●
Front mud flaps	●	●	●

● Standard equipment

* Single cab only





READY TO WORK FOR ALL ACTIVITIES

Single and double van cab, single and double chassis, platform cab, all profiles geared to your activity's needs and constraints. Whatever your model, take advantage of new high-performance and more fuel-efficient twin-turbo engines (from 130 hp to 180 hp), as well as the electric motor option.



Profitability

06
07

Renault Trucks Master

EURO 6 ENGINE OR ELECTRIC MOTOR

The engines, compliant with the Euro 6 d-temp or Euro VI D standards, are available in a wide number of capacities, all significantly reducing polluting emissions. Many driving assistance systems and a robotised gearbox ensure fuel consumption is kept under control. An all-electric version is also available.

BI-TURBO ENGINES AVAILABLE ON THE WHOLE RANGE

A wide range of WLTP or NEDC certified engines available to meet environmental and business constraints.



**UP TO
400 NM
TORQUE**

RENAULT TRUCKS MASTER Z.E.:

ZERO TAILPIPE EMISSIONS



RENAULT TRUCKS MASTER Z.E.

- All-electric version for accessing low emission environments
- Charges in 6 h
- 33 kW / h battery and 120 km of autonomy in actual use
- Available in van (including minibus conversion), platform cab and chassis cab

OPTIMISED FUEL CONSUMPTION



- 1 STOP & START SYSTEM**
standard on 145, 150, 165 and 180 hp engines.
- 2 ECO MODE**
Standard on all models with manual transmission to reduce fuel consumption.



ROBOTIC GEARBOX

for ease of use in urban operations and to control fuel consumption (on 150 and 180 hp front wheel drive models only).



GEAR CHANGING ASSISTANCE

optimise fuel consumption.

READY TO BODY FOR ALL ACTIVITIES

Renault Trucks Master features a modular structure, a removable rear crossmember and specific equipment to facilitate body mounting. Offering one of the most extensive vehicle length ranges on the market, it can meet all activities' needs.



A SITE DEDICATED TO BODY BUILDERS

providing all the information needed for your vehicle's body fitting (vehicle structure, bodymounting plans and instructions) via <http://bbportal.renault-trucks.com>



PRE-FITTING AND EQUIPMENT

to facilitate bodywork fitting and integration.



MODULAR CHASSIS STRUCTURE

for faster body mounting.



WIDE RANGE OF BODY LENGTHS

from 2,434 mm to 5,470 mm.



TIPPER VERSION

(mixed or steel) with or without cab toolbox*.



BOX BODIED VERSION

20 or 22 m³ with tail lift, deflector or Luton body.



TOWING HOOK*

for those applications that need to maximise GTW whilst towing.

*Optional.

OUTSTANDING LOADING CAPACITY AND VOLUME

Van volume from 5 to 17 m³, wide rear and side openings, allowing bulky objects to be loaded easily, one of the best payloads on the market: Renault Trucks Master is the ideal vehicle for meeting the needs of the most demanding activities.



SIDE DOOR WIDTH UP TO 1,270 MM
for loading europallets.



TIE-DOWN HOOKS
incorporated to ballast the load.

VEHICLE INTERIOR AND EXTERIOR ADAPTABLE FOR SPECIFIC NEEDS



L4 H3 REARWHEEL DRIVE VERSION

with a loading capacity of 17 m³,
4,383 mm of useable length and
2,048 mm of useable height.





UP TO 17M³ OF LOADING VOLUME

- 1 Up to 1,820 mm
- 2 1,580 mm
- 3 1,380 mm
- 4 Payloads up to 2,332 kg
- 5 5 ideal loading heights from 542 mm



TO LOAD UP TO 5 EUROPALETTES

made possible by a large surface
area on the single mount version.





ALWAYS READY TO WORK

With the Renault Trucks Master, you keep your promises and meet your customers' expectations perfectly.

Whatever happens, wherever you are, your vehicles are always operational and ready to complete their missions.



ROBUST AND RELIABLE UNDER ALL CONDITIONS

Tried and tested, robust axle and suspension systems guarantee maximum reliability of your utility vehicle under all conditions, including arduous off-road applications.

GTW UP TO 7.5 T

- 1 Up to 1,850 kg load capacity on the front axle (3.5 t to 4.5 t)
- 2 Steel protection sump guard under the engine
- 3 Load capacity on the rear axle of up to 3,200 kg (4.5 t twin wheel version)
- 4 Side member reinforcements on the chassis for added strength and durability
- 5 High ground clearance on 4x4 versions





RESILIENT FRONT BUMPER

for better impact resistance.



TWIN WHEELS

for maximum load capacity at 3.5t and 4.5t RWD models.



**A PAYLOAD
OF UP TO
2,332 KG**



MECHANICAL LEAF SUSPENSION

can operate in difficult conditions.



AIR SUSPENSION*

optimising comfort and maintaining a constant vehicle attitude regardless of load conditions.

* Optional.

PERFECTLY AT HOME ON ALL SURFACES

Technology and specific equipment give the Renault Trucks Master outstanding traction for operating on all surfaces.

AVAILABLE IN BOTH FRONT WHEEL DRIVE, REAR WHEEL DRIVE AND 4X4*

- 1 Twin tyres on 3.5 t to 4.5 t models deliver better traction on difficult surfaces
- 2 All weather tyres**
- 3 Steel protection under the engine**

*By Oberaigner GmbH
** Optional





EXTENDED GRIP

Electronic management for operating on all types of surface (sand, snow, mud, etc.), available as standard on both front wheel and rear wheel drives.



INTER-WHEEL DIFFERENTIAL LOCK ON RWD

ALWAYS AT YOUR SIDE

Renault Trucks supports you to ensure your working tool gives you maximum availability throughout its operational life.

A personalised maintenance plan is supplied with the vehicle to ensure maintenance frequency reflects actual usage. Start and Drive maintenance contracts up to 5 years are available. Our standard 3 year / 100,000 miles warranty gives you peace of mind right from the start.



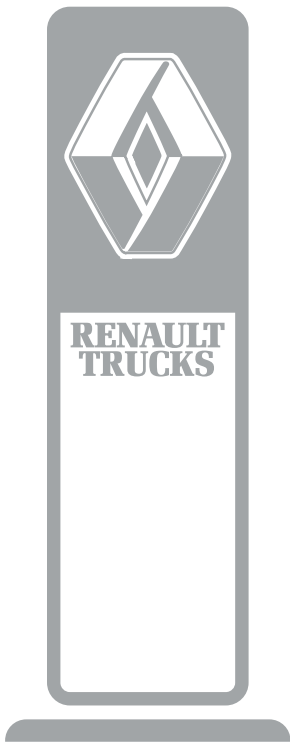

NETWORK

Over 1,600 service and repair points worldwide.



2 YEARS WARRANTY

With the 2-year extended warranty on spare parts fitted by an approved Renault Trucks repairer, you benefit from ideal protection and the best value for money.

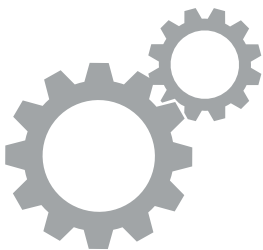

GENUINE

The Renault Trucks Genuine parts offer guarantees your vehicles' performance will be maintained.



MAINTENANCE PACKAGES

Maintenance packages for the Renault Trucks Master inform you in advance of the operations planned, how long they will take and the details of the maintenance to be carried out.



START & DRIVE

Maintenance and repair contracts tailored to your activity, respecting your budget and ensuring your working tool delivers maximum working availability.



RENAULT TRUCKS FINANCE AND INSURANCE

Tailor-made financing and insurance solutions for purchasing or renting your vehicles.



RENAULT TRUCKS 24/7

A network of experts answers you in 16 languages to provide assistance and troubleshooting operations, guaranteeing high quality service 7 days a week / 24 hours a day.

**BECAUSE A COMMERCIAL
VEHICLE MUST FACILITATE
YOUR WORK**



With Renault Trucks, you have a partner who will make everyday life easier. Renault Trucks Master is designed and equipped to ensure driver and passengers' comfort. It also simplifies loading and unloading operations provided through its excellent accessibility.





1 Cruise control or speed limiter

2 Driver or driver and passenger airbags, plus optional lateral airbags

3 3.5" driver customisable screen

4 Medianav navigation with DAB digital radio, TMC traffic information, Android Auto™ and Apple CarPlay smartphone replication

5 Consolidated and easy-access controls

6 Air conditioning

7 Over 22 L of storage space on the dashboard, open or closed

EVERYTHING WITHIN YOUR REACH

Multifunction steering wheel, cruise control and speed limiter, 7" touch screen navigation and driving equipment allowing drivers to focus on their job.



Comfort

24
25

Renault Trucks Master

WORKING COMFORT IN THE CAB

The spacious and modular cab offers driver and passengers superior comfort. Up to 105 L of useful storage space, making everyday work easier.



SINGLE CAB VERSION

2 or 3 seats.



DOUBLE CAB VERSION

up to 7 seats.



SUSPENDED SEAT (OPTIONAL)

adjustable in height and depth with adjustable headrest, central armrest and lumbar support for maximum comfort.



RETRACTABLE TABLET SHELF

incorporated into the dashboard for A4 documents.



LAPTOP COMPUTER SHELF

with storage, two bottle holders and swivel table on the back of the folding seat.



REAR BENCH STORAGE SPACE

accessed by lifting the seat in the double cab version.

WORKING COMFORT

Renault Trucks Master offers working comfort designed to make users' everyday life easier, including our tailored ex-factory body solutions and our Ready for Business range which have a wide variety of fully converted products.



DOORS OPEN UP TO 270°

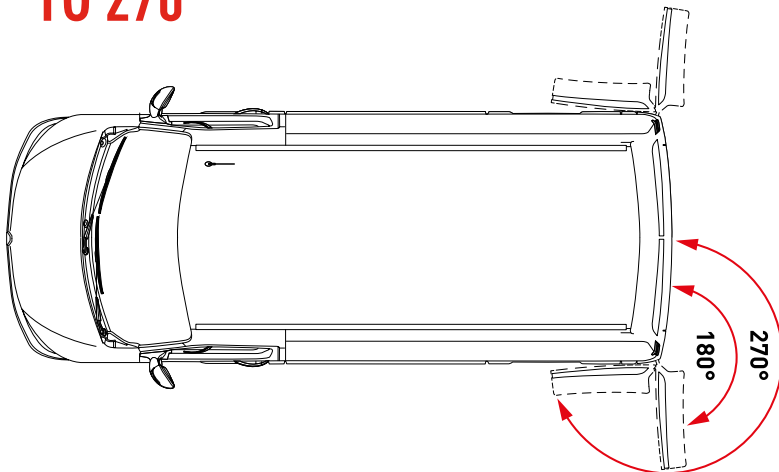

- 1 Low chassis height from 741 mm to facilitate loading and unloading operations
- 2 Optimised cab access with a first step at a height of 430 mm
- 3 Side loading threshold from 499 mm
- 4 Rear loading threshold from 542 mm
- 5 Rear grab handle



LOADING AREA ACCESS HANDLE

side door and rear door.



GRAB HANDLE*

for accessing the cab.



LED LIGHTING

in the loading area to work safely.



REAR ACCESS STEP

from 542 mm.



Accessories for a personal touch

* available as an accessory.

WORK IN SAFETY

With Renault Trucks, you enjoy numerous facilities for stress-free working guaranteeing safety for the driver, passengers and other road users.

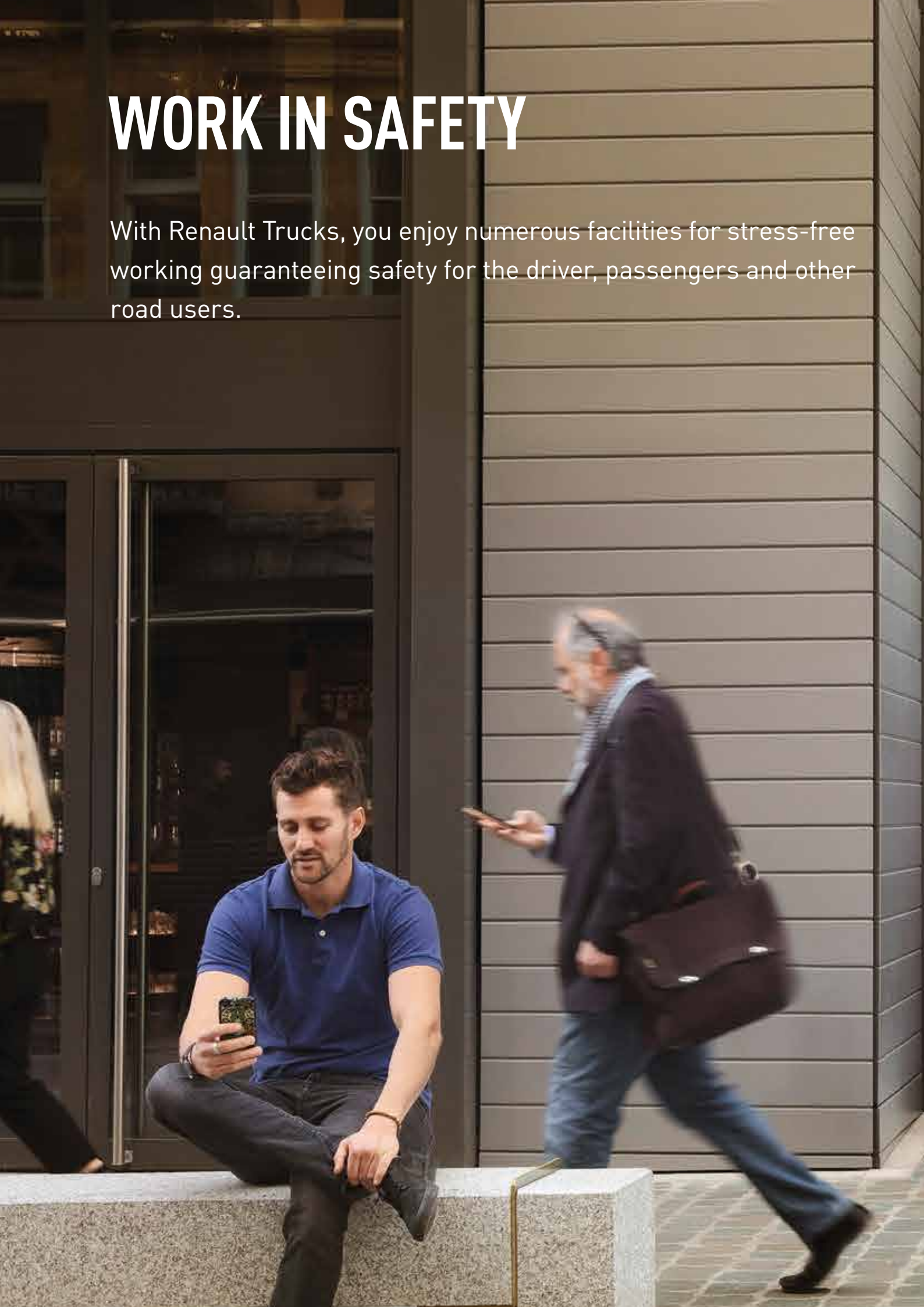



Protection

30
31

Renault Trucks Master

SAFETY FIRST!

Driver assistance technologies and different braking systems protect people and cargo. Numerous items of equipment further enhance driver safety.



ELECTRONIC STABILITY CONTROL - ESC

fitted as standard to help drivers maintain trajectory and prevent the vehicle from overturning in critical situations.



FRONT AND REAR PARKING SENSORS

emit an audible signal when an obstacle is detected.



LANE DEPARTURE WARNING

an audible signal warns the driver in the event of any involuntary deviation from the vehicle's trajectory.



HILL START ASSISTANCE

The brakes are maintained a few seconds after the pedal is released to facilitate hill starts.



SIDE WIND ASSISTANCE

This system helps the driver stay in the lane when the wind is coming from the side.



BLIND SPOT ALERT

Warns the driver of blind spot dangers by a warning light in the mirrors.

ACTIVE EMERGENCY BRAKING SYSTEM (AEBS) AVAILABLE THROUGHOUT THE RANGE



CAMERA

for the lane departure warning system and automatic light activation.



SENSOR

for the Active Emergency Braking System (AEBS).

OPTIMUM VISIBILITY IN ALL WEATHERS

Windscreen and mirror design deliver considerable gains in terms of visibility. The various lights and safety equipment guarantee maximum safety in all conditions and environments.

- 1 Indicators
- 2 LED daytime running lights
- 3 Main beam headlights
- 4 Dipped beam headlights





1 EXTRA WIDE BLIND SPOT MIRROR (OPTION)
in the sun visor.



2 WIDE ANGLE MIRRORS
electrically adjustable with integrated indicators.



3 CONSTANT REARVIEW (OPTION)
via a camera on the rear of the roof acting as a rearview mirror while driving.

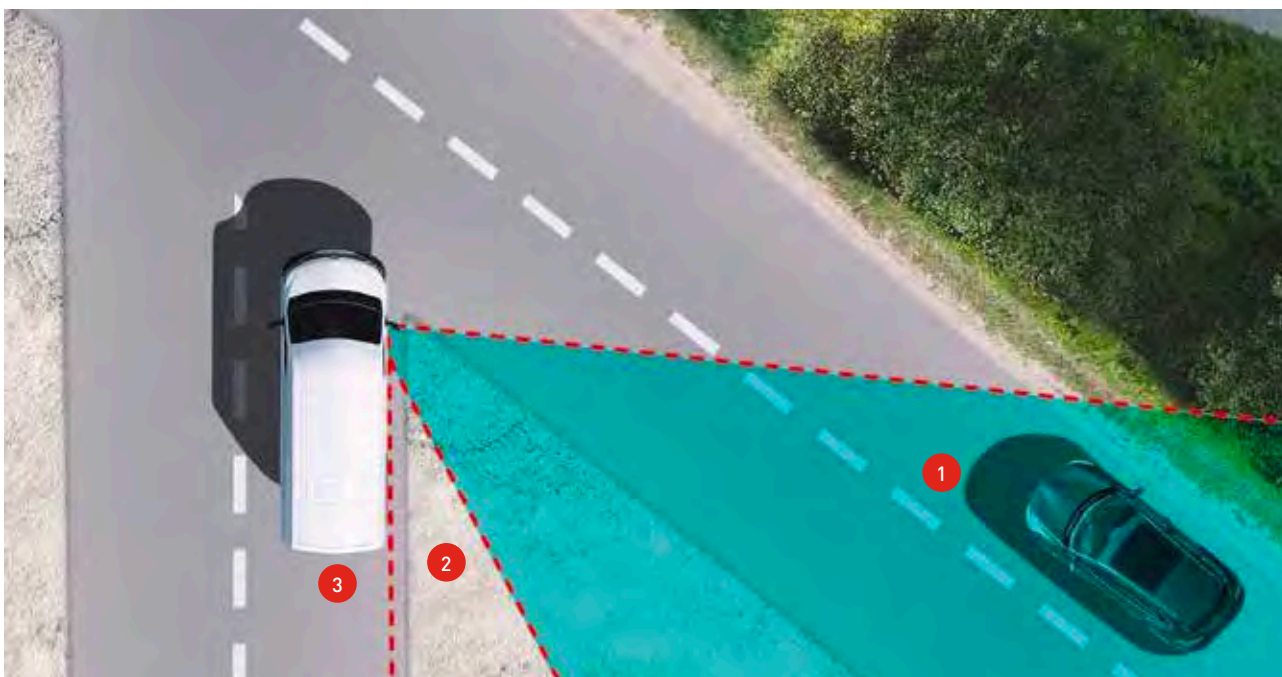

TECHNICAL CHARACTERISTICS

CHASSIS CAB AND PLATFORM CAB

- 1 Available in single front wheel drive, single rear wheel drive or twin wheel versions*
- 2 Simplified body fitting made possible by the modular chassis and a wide range of body lengths from 2,434 mm to 5,470 mm
- 3 Vehicle available in chassis or platform versions
- 4 Vehicle available in single or double cab versions**
- 5 2 cab heights available on the platform cab version
- 6 2 widths of mirrors available
- 7 Camera for lane departure warning system and automatic light switching
- 8 Cabs with 2 to 7 seats
- 9 Wide track option available on platform cab giving an extra 130 mm between wheel arches

*Platform cab only available in FWD

** Single cab only in platform cab version



SINGLE AND DOUBLE CAB VAN

1 Front parking sensors

2 Constant rearview vision

3 From 5 to 17 m³

4 A choice of 3 heights and 4 lengths

5 Cargo area access handles

6 Cabs with 2 to 7 seats



RANGE SUMMARY

	Front wheel drive	Rear wheel drive	
	Single tyres	Single tyres	Twin tyres
	Payload and road passenger transport	Heavy loads and towing and/or off-road	
Benefits	Loading threshold lowered by 13 mm	Improved maneuverability. Reduced turning radius, greater GTW.	
Engines	Euro 6 d-temp (Light Duty) Euro VI d (Heavy Duty)	Euro VI d (Heavy Duty)	
Gearbox	Manual 6-speed or robotised	6-speed manual	
GVW / GTW	3.3 t / 5.8 t 3.5 t / 6 t	3.5 t / 6 t	3.5 t / 7 t 4.5 t / 7.5 t
Van (single or double cab)	L1 (H1, H2) E10 (3182 mm) Short rear overhang	-	-
	L2 (H2, H3) E20 (3682 mm) Short rear overhang	-	-
	L3 (H2, H3) E30 (4332 mm) Short rear overhang	L3 (H2, H3) E20 (3682 mm) Long rear overhang	L3 (H2, H3) E20 (3682 mm) Long rear overhang
	-	L4 (H2, H3) E30 (4332 mm) Long rear overhang	L4 (H2, H3) E30 (4332 mm) Long rear overhang
Chassis cab (single or double cab)	L2 E20 (3682 mm) Short rear overhang	L2 E20 (3682 mm) Short rear overhang	L2 E20 (3682 mm) Normal rear overhang
	L3 E30 (4332 mm) Short rear overhang	L3E30 (4332 mm) Short rear overhang	L3 E20 (3682 mm) Long rear overhang
	-	-	L4 E30 (4332 mm) Long rear overhang
Platform cab	L2 (H1, H2) E20 (3682 mm) Short rear overhang	-	-
	L3 (H1, H2) E30 (4332 mm) Short rear overhang	-	-

Z.E. (ELECTRIC VERSION)

Model	Version	Engine type	Gearbox	Battery	Operating range / Emissions	Volume / Payload	Tyres
Van (Front wheel drive)	L1H1	R75 57 kW 76 hp Synchronous with wound rotor motors	Reducer	Lithium-Ion 33 kWh 400 V	NEDC: 200 km* actual 120 km** CO ₂ : 0 g / km	8 m ³ / 1,094 kg	215/65 R16
	L1H2					9 m ³ / 1,066 kg	
	L2H2					10.8 m ³ / 1,022 kg	
	L3H2					13 m ³ / 941 kg	
Cab platform (Front wheel drive)	L2H1	Maximum torque: 225 Nm Max power: 57 kW	1 forward gear 1 reverse gear	255 kg 48 modules 192 cells	NEDC: 200 km* Actual: depending on body type CO ₂ : 0 g / km	Volume of loading by body type	
	L3H1	Maximum speed: 80 km / h				Payload without bodywork 1,341/1,319 kg	

* NEDC: New European Driving Cycle, the European standard for measuring emissions and consumption - Estimation / certification underway

** Operating range over 80 km even under the most severe conditions (maximum payload, frequent stops in urban environments, low temperatures).

Charger type	Charging station	Power requirement	Charging time (from 0% to 100%)
Domestic power outlet	Home / Office	2.3 kW / 10 A	17 hours
Domestic power outlet (Green'Up)	Home / Office	3.3 kW / 14 A	12 hours
Wall charger or public charging station	Home / Office / Public road	3.7 kW / 14 A	11 hours
	Home / Office / Public road	7 kW	6 hours
Public charging station	Public highway	22 kW	6 hours
	Public highway	43 kW	6 hours

DRIVE TRAIN

	Engine	Power	Max.power / Max torque	Gearbox	Urea vol. full / Reserve
Light duty Euro 6 d-temp	4 cylinders 2.3 L Twin-Turbo	135 hp	89 kW / 360 Nm	Manual 6 speed	28.3 L / 1.2 L
		150 hp Stop & Start	110 kW / 385 Nm	Manual 6 speed / Robotic 6 speed	
		180 hp Stop & Start	132 kW / 400 Nm	Manual 6 speed / Robotic 6 speed	
Heavy duty Euro VI d	4 cylinders 2.3 L Twin-Turbo	130 hp (drive)	96 kW / 330 Nm	Manual 6 speed	21.8 L / 2.3 L
		145 hp Stop & Start	107 kW / 360 Nm		
		165 hp Stop & Start	120 kW / 380 Nm		

LIGHT DUTY EURO 6D-TEMP MOTORS

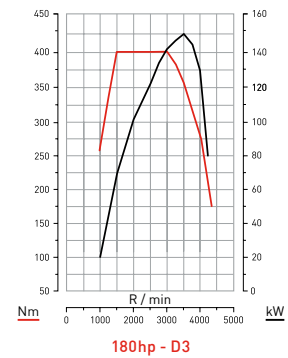
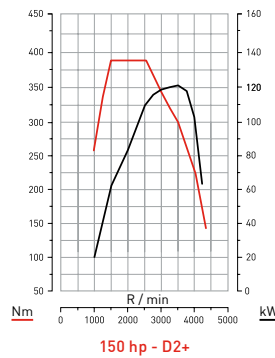
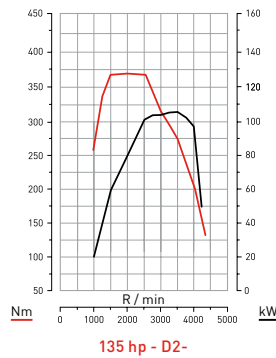

HEAVY DUTY MOTORS EURO VI D

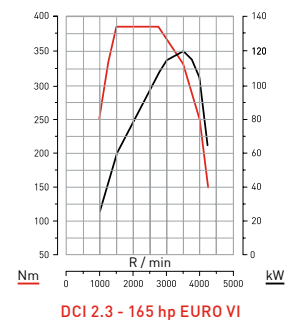
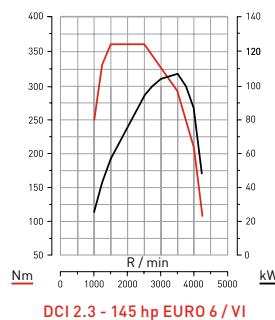
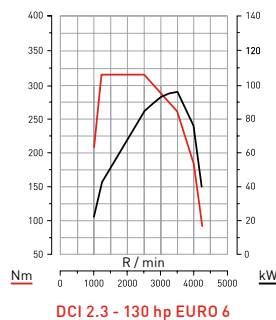

→ **Eco Mode:**
on all manual gearbox speeds

→ **Stop and start:**
on the following engines:
145, 150, 165 and 180 hp

→ **Fuel tank:**
80 L or 105 L

→ **Ad Blue tank:**
28.3 L (Light Duty) and
21.8 L (Heavy Duty)

BRAKING AND TYRES

	3.3 t	3.5 t	3.5 t (Rear wheel drive)	4.5 t (Rear wheel drive)
Brakes	AV: ventilated discs - AR: solid discs at the rear			
Dynamic vehicle control	ESC (ASR + HSA + TSA + ROM + RMF)			
Tyres (all-weather optional)	215/65 R16	225/65 R16	235/65 R16	195/75 R16

ESC (Electronic Stability Control) is standard on all versions and includes the following technologies:

→ **Extended grip / ASR (Electronic Traction Control)**

→ **Hill Start Aid**

→ **Trailer Swing Assist (Trailer Stability Function)**

→ **ROM / RMF (Anti-rollover control system)**

WEIGHTS AND DIMENSIONS

CHASSIS CAB

	Front wheel drive		Rear wheel drive					
	L2 Single wheel	L3 Single wheel	L2 Single wheel	L2 Twin wheels	L3 Single wheels	L3 Twin wheels	L4 Twin wheels	
GVW / GTW	3.5 / 6 t	3.5 / 6 t	3.5 / 6 t	3.5 / 7 t	3.5 / 6 t	3.5 / 7 t	3.5 / 7 t 4.5 / 7.5 t	
Total length	5670 mm	6320 mm	5670 mm	5670 mm	6320 mm	6220 mm	6870 mm	
Front overhang	869 mm							
Wheelbase	E20 3682 mm	E30 4332 mm	E20 3682 mm	E20 3682 mm	E30 4332 mm	E20 3682 mm	E30 4332 mm	
Rear overhang	1119 mm		1119 mm			1669 mm		
Total width (with standard mirrors / large supports)	2470/2654 mm							
Floor / cab roof height	2265 mm	2258 mm	2284 mm	2283 mm	2276 mm	2283 mm	2273 mm	
Body length range (min / max)	3184/ 3466 mm	3834/ 4840 mm	3184/ 4295 mm	3184/ 3993 mm	3834/ 5746 mm	3734/ 3993 mm	4384/ 5470 mm	
Floor threshold height (min / max)	581/585 mm		166 mm					
Lateral sill height	735 / 740 mm	736/ 741 mm	771/ 774 mm	784/ 787 mm	771/ 775 mm	784/ 787 mm	786/ 789 mm	
Max. usable body width (with standard mirrors / large supports)	2170/2350 mm							
Turning radius between kerbs / walls	13.6 m / 14.1 m	15.7 m / 16.2 m	13.6 m / 14.1 m			15.7 m / 16.2 m	13.6 m / 14.1 m	15.7 m / 16.2 m
Maximum load on front axle	1850 kg							
Maximum load on rear axle	2100 kg		2300 kg				2300 kg / 3200 kg	

DOUBLE CHASSIS CAB

	Front wheel drive		Back wheel drive			
	L2 Mounted single	L3 Mounted single	L2 Mounted single	L3 Mounted single	L3 Twin mounted wheels	L4 Twin mounted wheels
GVW / GTW	3.5 / 6 t	3.5 / 6 t	3.5 / 6 t	3.5 / 6 t	3.5 / 7 t 4.5 / 7.5 t	3.5 / 7 t 4.5 / 7.5 t
Total length	5670 mm	6320 mm	5670 mm	6320 mm	6220 mm	6870 mm
Front overhang	869 mm					
Wheelbase	E20 3682 mm	E30 4332 mm	E20 3682 mm	E30 4332 mm	E20 3682 mm	E30 4332 mm
Rear overhang	1119 mm		1119 mm		1669 mm	
Total width (with standard rearview mirrors / large supports)	2470/2654 mm					
Floor / cab roof height	2265 mm	2258 mm	2284 mm	2276 mm	2283 mm	2273 mm
Body length range (min / max)	2434/ 2516 mm	3084/ 4044 mm	2434/ 3232 mm	2985/ 3416 mm	3734/ 3993 mm	4384/ 5470 mm
Floor threshold height (min / max)	581/585 mm		166 mm			
Lateral threshold height	735/740 mm		771/774 mm	771/775 mm	784/787 mm	786/789 mm
Max. usable body width (with standard mirrors / large supports)	2170/2350 mm					
Turning radius between kerbs / walls	13.6 m / 14.1 m	15.7 m / 16.2 m	13.6 m / 14.1 m	15.7 m / 16.2 m	13.6 m / 14.1 m	5.7 m / 16.2 m
Maximum load on front axle	1850 kg					
Maximum load on rear axle	2100 kg		2300 kg		2300 kg / 3200 kg	

CABS

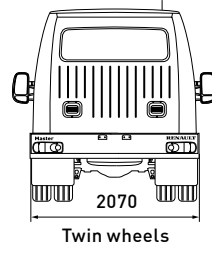
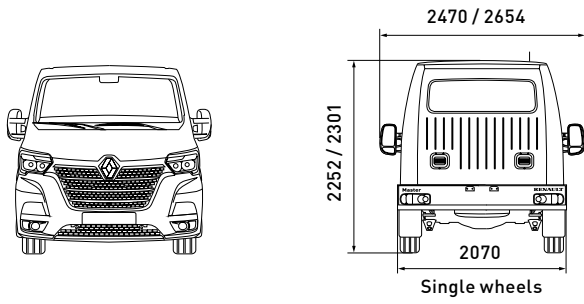

SINGLE WHEELS

L2 SINGLE CAB

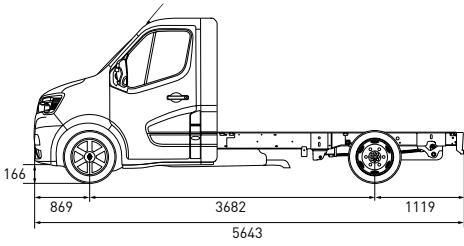

L2 DOUBLE CAB

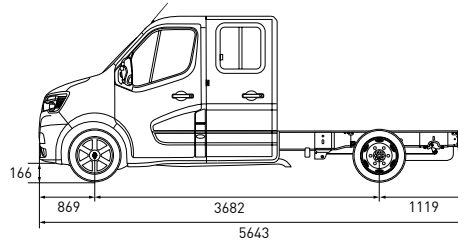

L3 SINGLE CAB

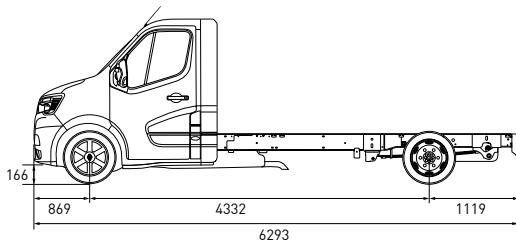

L3 DOUBLE CAB

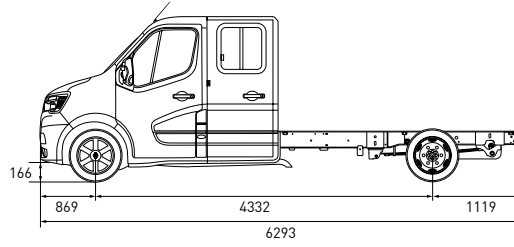

TWIN WHEELS

L2 SINGLE CAB

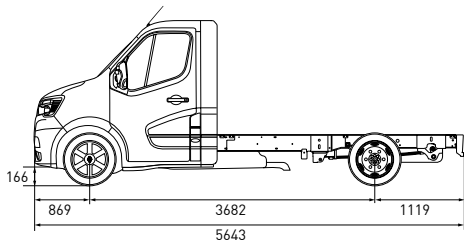

L3 SINGLE CAB

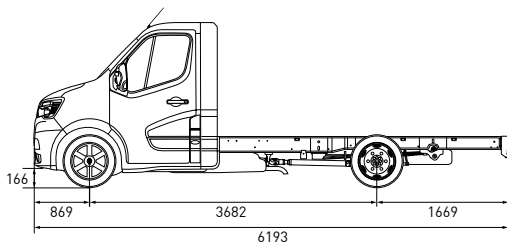

L3 DOUBLE CAB

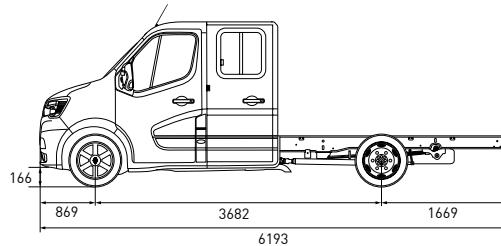

L4 SINGLE CAB

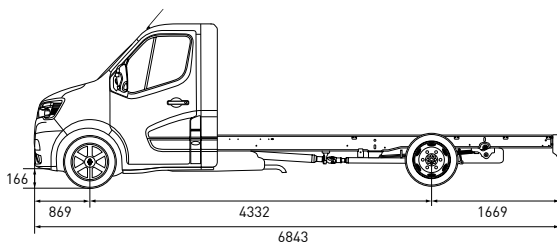

L4 DOUBLE CAB

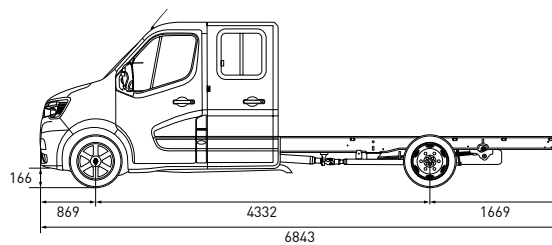

WEIGHTS AND DIMENSIONS

PLATFORM CAB

	Front wheel drive			
	L2 H1 Single wheels	L2 H2 Single wheels	L3H1 Single wheels	L3H2 Single wheels
GVW / GTW	3.5 / 6 t	3.5 / 6 t	3.5 / 6 t	3.5 / 6 t
Total length	5670 mm	6320 mm	5670 mm	6320 mm
Front overhang	869 mm			
Wheelbase	E20 3682 mm	E30 4332 mm	E20 3682 mm	E30 4332 mm
Rear overhang	1119 mm		1119 mm	
Total width (with standard mirrors / large supports)	2,470 / 2,654 mm			
Cab roof / floor height	2265 mm	2258 mm	2284 mm	2276 mm
Useful road length (min / max)	2434/2516 mm	3084/4044 mm	2434/3232 mm	2985/3416 mm
Floor threshold height (min / max)	581/585 mm		166 mm	
Max. body width range (with standard mirrors / large supports)	2170/2350 mm			
Turning circle between kerbs / walls	13.6 m / 14.1 m	15.7 m / 16.2 m	13.6 m / 14.1 m	15.7 m / 16.2 m
Maximum load on front axle	1850 kg			
Maximum load on rear axle	2100 kg		2300 kg	

PLATFORM CAB

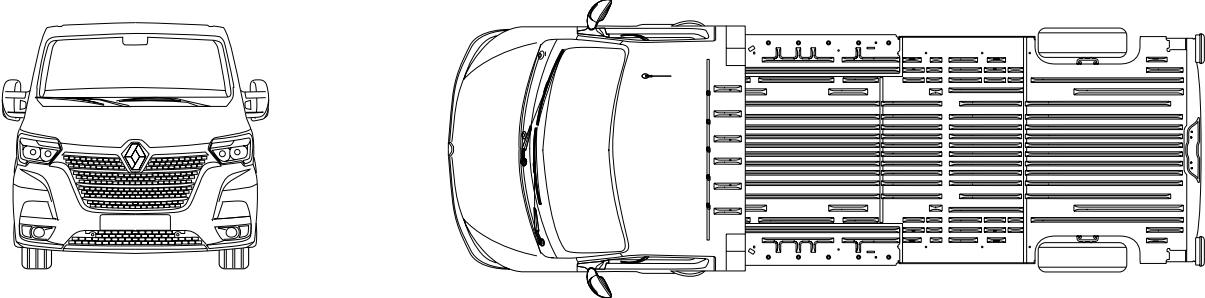

FLOOR

L2H1

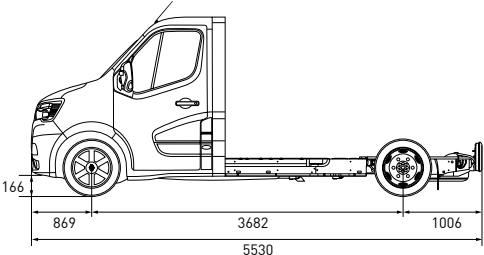

L2H2

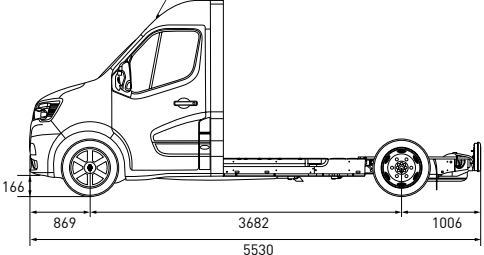

L3H1

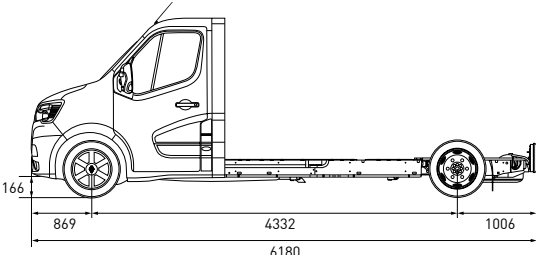

L3H2

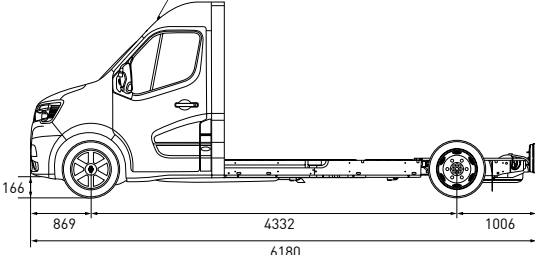

WEIGHTS AND DIMENSIONS

VAN

FRONT WHEEL DRIVE	L1H1 Single wheels	L1H2 Single wheels	L2H2 Single wheels	L2H3 Single wheels	L3H2 Single wheels	L3H3 Single wheels
GVW / GTW	3.3 / 5.8 t 3.5 / 6 t	3.3 / 5.8 t 3.5 / 6 t	3.3 / 5.8 t 3.5 / 6 t	3.3 / 5.8 t 3.5 / 6 t	3.3 / 5.8 t 3.5 / 6 t	3.3 / 5.8 t 3.5 / 6 t
Total length	5075 mm		5575 mm		6225 mm	
Front overhang	869 mm					
Wheelbase	3182 mm		3682 mm		4332 mm	
Overhang	1024 mm					
Total width (with standard mirrors)	2470 mm					
Height floor / cab roof	2310 mm	2503 mm	2499 mm	2749 mm	2549 mm	2815 mm
Turning diameter between kerbs / walls	12 / 12.5 m		13.6 / 14.1 m		15.7 / 16.2 m	
Maximum load on front axle	1650/1850 kg					
Maximum load on rear axle	1900/2100 kg					
Cargo area						
Useable volume	8 m ³	9 m ³	10.8 m ³	12.3 m ³	13 m ³	14.8 m ³
Available interior length	2583 mm		3083 mm		3733 mm	
Available interior length at 1.1 m	2530 mm		3030 mm		3680 mm	
Available height	1700 mm	1894 mm	1894 mm	2144 mm	1894 mm	2144 mm
Available interior width	1765 mm					
Width between wheel arches	1380 mm					
Sliding side door(s)						
Height	1581 mm	1780 mm	1780 mm			
Width	1050 mm		1270 mm			
Rear door						
Entrance height	1627 mm	1820 mm	1820 mm			
Width (at 169 mm from the floor)	1580 mm					
Loading threshold (min / max)	546 / 564 mm	544 / 563 mm	545 / 562 mm	543 / 556 mm	543 / 557 mm	542 / 555 mm
Minimum ground clearance	182 mm		174 mm	173 mm	172 mm	169 mm

REAR WHEEL DRIVE

	L3H2 Single wheels	L3H2 Twin wheels	L3H3 Single wheels	L3H3 Twin wheels	L4H2 Single wheels	L4H2 Twin wheels	L4H3 Single wheels	L4H3 Twin wheels
GVW / GTW	3.5 / 6 t	3.5 / 7 t 4.5 / 7.5 t	3.5 / 6 t	3.5 / 7 t 4.5 / 7.5 t	3.5 / 6 t	3.5 / 7 t 4.5 / 7.5 t	3.5 / 6 t	3.5 / 7 t 4.5 / 7.5 t
Total length	6225 mm				6875 mm			
Front overhang	869 mm							
Wheelbase	3682 mm				4332 mm			
Rear overhang	1674 mm							
Total width (with standard mirrors)	2470 mm							
Floor / cab roof height	2549 mm		2815 mm		2557 mm		2808 mm	
Turning radius between kerbs / walls	13.6 / 14.1 m				15.7 / 16.2 m			
Maximum load on front axle	1850 kg							
Maximum load on rear axle	2300 / 3200 kg							
Cargo area								
Available volume	12.4 m ³		14.2 m ³		14.9 m ³		17 m ³	
Available interior length	3733 mm				4383 mm			
Internal available length at 1.1 m	3680 mm				4330 mm			
Available height	1798 mm		2048 mm		1798 mm		2048 mm	
Available interior width	1765 mm							
Width between wheel arches	1380 mm	1080 mm	1380 mm	1080 mm	1380 mm	1080 mm	1380 mm	1080 mm
Sliding side door(s)								
Height	1684 mm							
Width	1270 mm							
Rear door								
Entrance height	1724 mm							
Width (at 169 mm from the floor)	1580 mm							
Loading threshold (min / max)	674/ 696 mm	706/ 724 mm	674/ 696 mm	706/ 724 mm	682/ 717 mm	704/ 717 mm	680/ 715 mm	702/ 715 mm
Minimum ground clearance	197 mm	181 mm	197 mm	181 mm	167 mm			

WEIGHTS AND DIMENSIONS

DOUBLE CAB VAN

SINGLE WHEELS	L1H1 Single wheels	L1H2 Single wheels	L2H2 Single wheels	L3H2 Single wheels
GVW / GTW	3.3 / 5.8 t 3.5 / 6 t	3.3 / 5.8 t 3.5 / 6 t	3.3 / 5.8 t 3.5 / 6 t	3.3 / 5.8 t 3.5 / 6 t
Total length	5075 mm		5575 mm	6225 mm
Front overhang	869 mm			
Wheelbase	3182 mm		3682 mm	4332 mm
Rear overhang	1024 mm			
Total width (with standard mirrors)	2470 mm			
Height floor / cab roof	2310 mm	2503 mm	2499 mm	2549 mm
Turning radius between kerbs / walls	12 / 12.5 m		13.6 / 14.1 m	15.7 / 16.2 m
Maximum load on front axle	1650/1850 kg			
Maximum load on rear axle	1900/2100 kg			
Cargo area				
Useful volume	5 m ³	5.3 m ³	6.9 m ³	9 m ³
Useful interior length at 0.4 m	1716 mm		2175 mm	2825 mm
Internal available length at 1.1 m	1531 mm		1990 mm	2640 mm
Useful height	1700 mm	1894 mm	1894 mm	
Interior available width	1765 mm			
Width between wheel arches	1380 mm			
Sliding side door (s)				
Height	1581 mm	1780 mm	1780 mm	
Width	1050 mm		1270 mm	
Back door				
Entrance height	1627 mm	1820 mm	1820 mm	
Width (at 169 mm from the floor)	1580 mm			
Loading threshold (min / max)	546/564 mm	544/563 mm	545/562 mm	543/557 mm
Minimum ground clearance	182 mm		174 mm	172 mm

REAR WHEEL DRIVE

	L3H2 Single wheel	L3H2 Twin wheels
GVW / GTW	3.5 / 6 t	3.5 / 7 t 4.5 / 7.5 t
Total length	6225 mm	
Front overhang	869 mm	
Wheelbase	3682 mm	
Rear overhang	1674 mm	
Total width (with standard mirrors)	2470 mm	
Height floor / cab roof	2549 mm	
Turning radius between kerbs /walls	13.6 / 14.1 m	
Maximum load on front axle	1850 kg	
Maximum load on rear axle	2300/3200 kg	
Cargo area		
Available volume	8.3 m ³	
Available interior length at 0.4 m	2825 mm	
Internal length available at 1.1 m	2640 mm	
Available height	1798 mm	
Useful available width	1765 mm	
Width between wheel arches	1380 mm	1080 mm
Sliding side door (s)		
Height	1684 mm	
Width	1270 mm	
Rear door		
Entrance height	1724 mm	
Width (at 169 mm from the floor)	1580 mm	
Loading threshold (min / max)	674/696 mm	706/724 mm
Minimum ground clearance	197 mm	181 mm

CABS

VAN

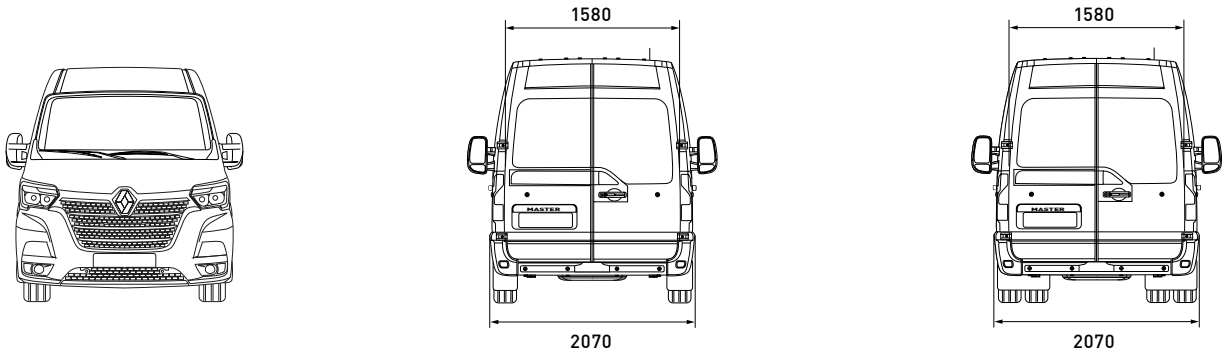

L1H1

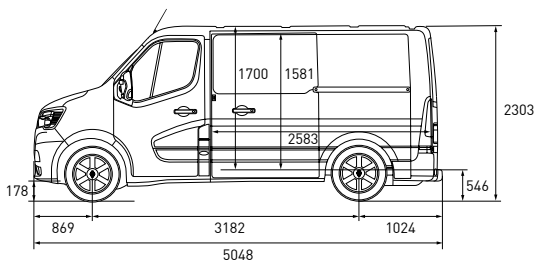

L1H2

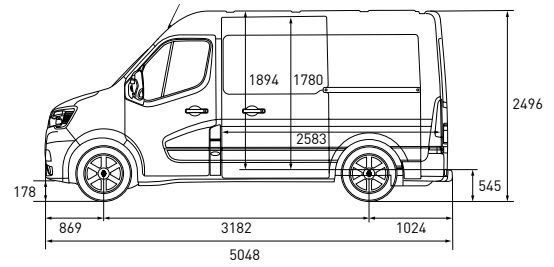

L2H2

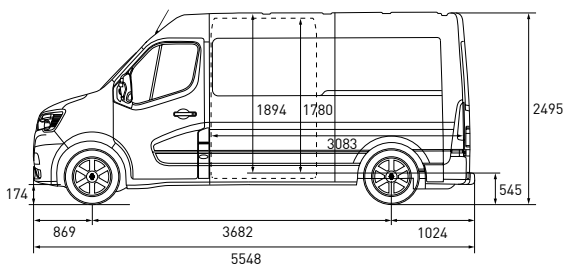

L2H3

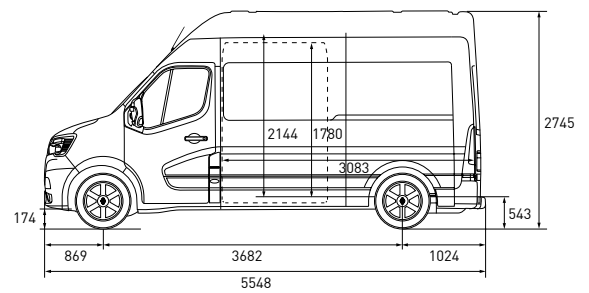

L3H2 SINGLE WHEELS

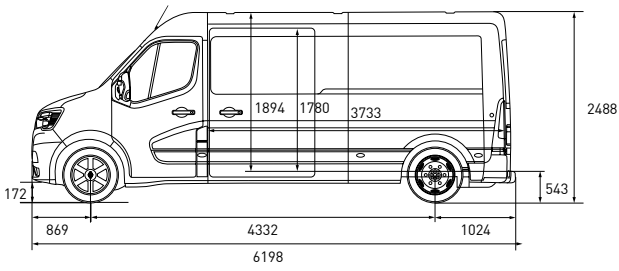

L3H3 SINGLE WHEELS

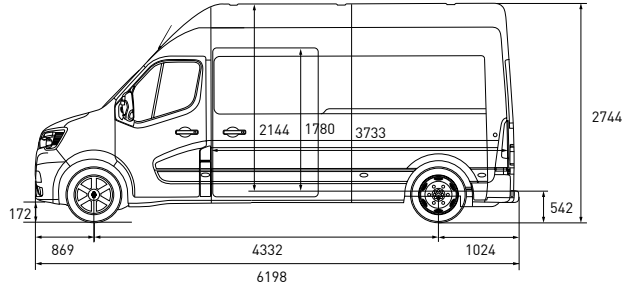

L3H2 REAR WHEEL DRIVE

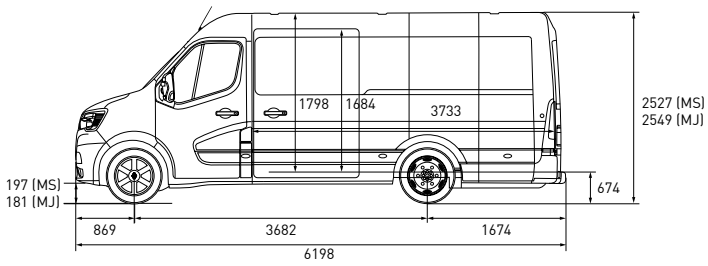

L3H3 REAR WHEEL DRIVE

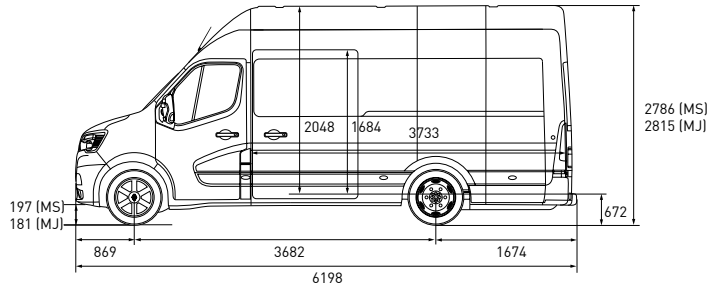

L4H2 REAR WHEEL DRIVE

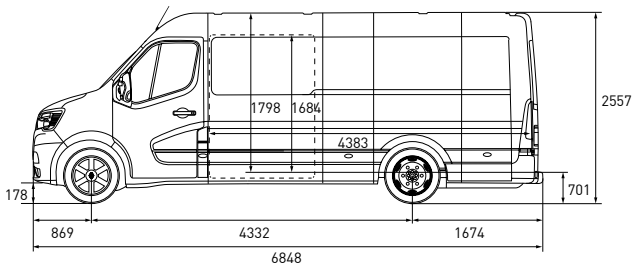

L4H3 REAR WHEEL DRIVE

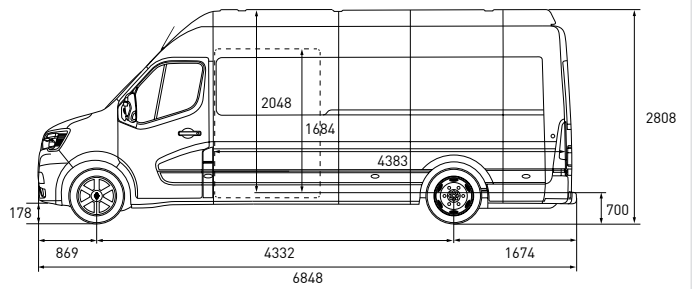

FINISHES

SEAT COLOUR SCHEME



Imitation leather



Kaleido

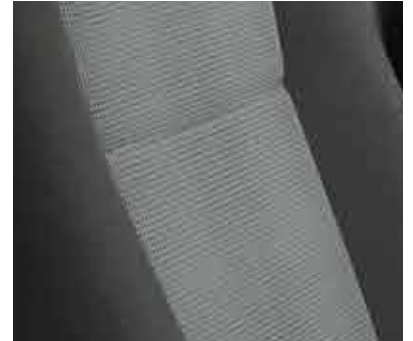

Carbon fabric

RIMS



Hub cap



Small hubcap



Large hubcap



Aluminum rim

RADIATOR GRILLES



Standard grille on Red EDITION Entry



Chrome grille on Red EDITION Exclusive

ACCESSORIES



6 mm polypropylene side walls and non-slip floor



Novestra rubber mat



Textile carpet



Red EDITION covers and rugs



Super Aquila seat cover



Transverse roof bars



Armlock kit



Cooler



Aluminum trunk threshold

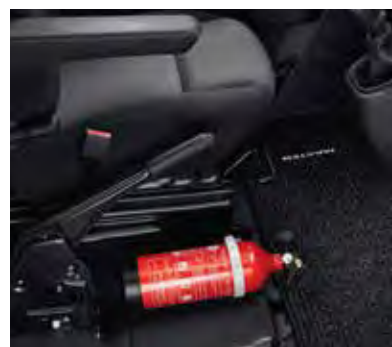

Fire extinguisher and bracket

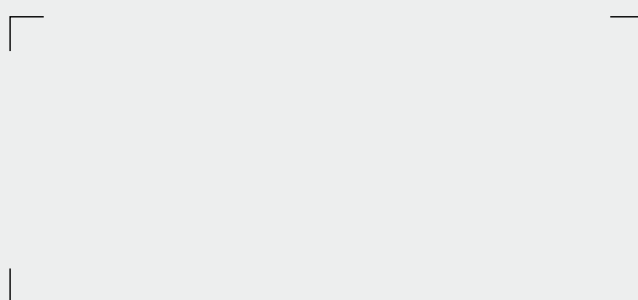

We recommend Renault Trucks Oils.
Dimensions and specifications are given for information purposes only.
The manufacturer reserves the right to modify them without notice.
Renault Trucks SAS with a capital of € 50,000,000 -
954,506,077 RCS Lyon



renault-trucks.co.uk



01/2020

